



PAUL UNO BE MBdgSc MIE(Aust) CPEng NER APEC Engineer IntPE(Aus)

- Over 40 years of experience in the design and construction industry.
- Former Senior Part-Time Lecturer – UNSW and USyd.
- Current chairman of Australian Standards BD-066 Precast & Tilt Up code (AS3850).

Livestreamed via



PROGRAMME 8 hours of CPD

(8.30am Zoom invite will be emailed)

9.00 - 11.00 Session 1

- CONCRETE PIPE MATERIALS, MANUFACTURE, PIPE TYPES AND TESTING

- Materials that are used to manufacture reinforced concrete pipes.
- Cement types include GP, SL and HE cement as well as SCM's (supplementary cementitious materials) such as flyash.
- Reason why some concrete pipes use elliptical steel reinforcement instead of circular steel reinforcement.
- Concrete pipe load class and the requirements of crack control for testing in accordance with AS/NZS 4058-2007.
- Other tests include hydrostatic testing, absorption testing and durability requirements e.g. impermeability limits, chloride and sulphate concentration limits.

11.00 - 11.15 Morning Break

11.15 - 1.00 Session 2

- SOIL PROPERTIES, PIPE SUPPORT AND BEDDING FACTORS

- Soil classification codes
 - GW vs SC
 - Soil Cohesion parameters
 - Requirements and differences between backfill, ordinary fill and select fill
 - Requirements for pipe bedding, haunch zones, side zones and overlay fill zones
 - Dry Density Ratio vs Density Index
 - Bedding Factors
 - Support Types (eg U vs H vs HS).
- Tutorial

1.00 - 1.30 Lunch Break

CALCULATORS REQUIRED



1.30 - 3.00 Session 3

- CONCRETE PIPE DESIGN LOADS AND EQUATIONS

- History of pipe formulas and the people behind these famous equations e.g. Marston, Spangler, Moser, Folkman etc.
- Pipeline definition of trench vs embankment.
- Formulas in AS/NZS3725-2007 (derivations provided).
- Trench theory, positive and negative projection in embankments (both complete and incomplete), settlement ratios, the effect of soil parameters K and u values on the design as well as jacked pipe systems.
- Various loads that can be applied to pipeline systems e.g. Construction loads, Road vehicle loads (including load distribution through fill using Boussinesq equations), Railway loads and Water loads.
- Tutorial

3.00 - 3.15 Afternoon Break

3.15 - 5.00 Session 4

- CONCRETE PIPE DESIGN EXAMPLES AND SOFTWARE

- Design worked examples.
- Registrants are guided through six (6) worked examples (in detail). They are then given two (2) detailed tutorial questions to solve by hand using the equations and steps shown earlier.
- Registrants are shown how to quickly solve these same (8) examples using the Concrete Pipe Association of Australia CPAA software program 'PIPECLASS Version 3.0'
- All attendees are encouraged to bring along their laptops with the software loaded or have it supplied free on the day so that the software tutorial exercises can be carried out.

Certificate of Attendances will be emailed

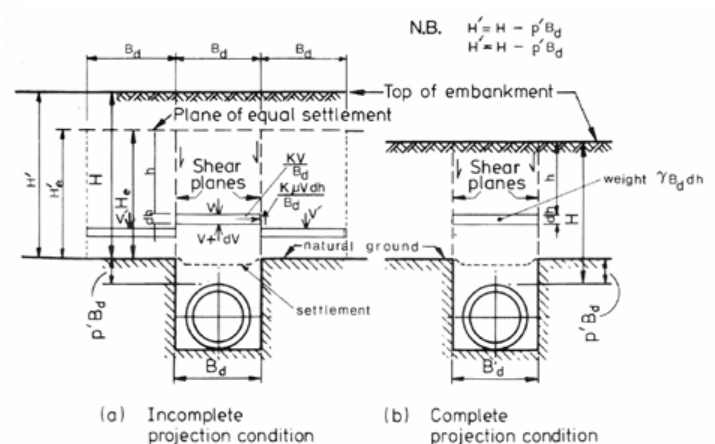

- One day course – \$710 pp

FURTHER INFORMATION

- (02) 9899 7447
- +61 413 998 031
- registrations@etia.net.au

- To register, visit our website www.etia.net.au
- OR scan the QR Code.

